

Human Tissue Kallikreins: A Family of New Cancer Biomarkers

ELEFThERIOS P. DIAMANDIS* and GEORGE M. YOUSEF

Kallikreins are a subgroup of the serine protease enzyme family. Until recently, it was thought that the human kallikrein gene family contained only three members. In the past 3 years, the entire human kallikrein gene locus was discovered and found to contain 15 kallikrein genes. Kallikreins are expressed in many tissues, including steroid hormone-producing or hormone-dependent tissues such as the prostate, breast, ovary, and testis. Most, if not all, kallikreins are regulated by steroid hormones in cancer cell lines. There is strong but circumstantial evidence linking kallikreins and cancer. Prostate-specific antigen (PSA; hK3) and, more recently, human glandular kallikrein (hK2) are widely used tumor markers for prostate cancer. Three other kallikreins, hK6, hK10, and hK11, are emerging new serum biomarkers for ovarian and prostate cancer diagnosis and prognosis. Several other kallikreins are differentially expressed at both the mRNA and protein levels in various endocrine-related malignancies, and they have prognostic value. The coexpression of many kallikreins in the same tissues (healthy and malignant) points to the possible involvement of kallikreins in cascade enzymatic pathways. In addition to their diagnostic/prognostic potential, kallikreins may also emerge as attractive targets for therapeutics.

© 2002 American Association for Clinical Chemistry

Until recently, it was thought that the human kallikrein gene locus contained only three genes: *KLK1*,¹ which encodes for pancreatic renal kallikrein (hK1); *KLK2*, which encodes for human glandular kallikrein (hK2); and *KLK3*, which encodes for prostate-specific antigen (PSA; hK3).

Several early estimates of the size of the human kallikrein gene family suggested that, in contrast to rodents, the human kallikrein family has no more than three genes (1). Around 1995, several independent research groups began reporting the cloning of new serine proteases that colocalize at the chromosomal region 19q13.4 and share a high degree of homology with the three known kallikreins. Extensive work by us and others led to the cloning of all 15 members of the human kallikrein gene family. Table 1 summarizes the first GenBank submission, the first report on, and the initial and official name of each of the 15 kallikreins.

The Human Kallikrein Gene Locus

The human kallikrein gene locus spans a region of 261 558 bp on chromosome 19q13.4. It is formed of 15 tandemly localized kallikrein genes with no intervention from other genes and is the largest cluster of serine proteases within the human genome. The first report on the expanded human kallikrein multigene locus appeared in 1999 and in an updated form in 2000 (2–4). The same locus was characterized later by others (5, 6). The last member, *KLK15*, was cloned in 2001 (7). Centromeric to the *KLK1* gene lies a nonkallikrein gene, testicular acid phosphatase (*ACPT*) (8). Telomeric to the last kallikrein gene, *KLK14*, lies another nonkallikrein gene, *Siglec 9*, a member of the *Siglec* multigene family (9, 10). The kallikrein genes in the locus are tightly packaged, with the distances between two adjacent genes ranging from as little as 1.5 kb (*KLK1* and *KLK15*) to 32.5 kb (*KLK4* and *KLK5*). A genomic map of the locus is presented in Fig. 1. No evidence exists for the presence of pseudogenes in this chromosomal region.

We recently constructed the first detailed map of the human kallikrein gene locus with single-base-pair accuracy and defined the direction of transcription of all genes

Department of Pathology and Laboratory Medicine, Mount Sinai Hospital, Toronto, Ontario, Canada, and Department of Laboratory Medicine and Pathobiology, University of Toronto, Toronto, Ontario, M5G 1X5 Canada.

*Address correspondence to this author at: Department of Pathology and Laboratory Medicine, Mount Sinai Hospital, 600 University Ave., Toronto, Ontario, M5G 1X5 Canada. E-mail ediamandis@mtsinai.on.ca.

Received March 26, 2002; accepted May 14, 2002.

¹Nonstandard abbreviations: *KLK* and hK, human kallikrein gene and protein, respectively; PSA, prostate-specific antigen (hK3); RT-PCR, reverse transcription-PCR; IGFBP, insulin-like growth factor binding protein; and uPA, urokinase-type plasminogen activator.

Table 1. Historical aspects of new human kallikrein gene discovery.^a

Official kallikrein name	Name when first cloned	First GenBank submission	First publication
<i>KLK4</i>	<i>Prostase</i>	AF113141	(24)
<i>KLK5</i>	<i>KLK-L2</i>	AF135028	(23)
<i>KLK6</i>	<i>Neurosin</i>	D78203 (mRNA) AF149289 (Full gene)	(73) (22)
<i>KLK7</i>	<i>HSCCE^b</i>	L33404 (mRNA) AF166330 (Full gene)	(74) (13)
<i>KLK8</i>	<i>Neuropsin</i>	AB009849	(75)
<i>KLK9</i>	<i>KLK-L3</i>	AF135026	(76)
<i>KLK10</i>	<i>NES1</i>	NM_002776 (mRNA) AF055481 (Full gene)	(58) (77)
<i>KLK11</i>	<i>TLSP</i>	AB012917 (mRNA) AF164623 (Full gene)	(78) (79)
<i>KLK12</i>	<i>KLK-L5</i>	AF135025	(28)
<i>KLK13</i>	<i>KLK-L4</i>	AF135024	(14)
<i>KLK14</i>	<i>KLK-L6</i>	AF161221	(27)
<i>KLK15</i>	<i>KLK15</i>	AF242195	(7)

^a A brief history describing the discovery of the three classic kallikreins has been published in a recent review (54). The patent literature is not included in this table.

^b *HSCCE*, human stratum corneum chymotryptic enzyme; *NES1*, normal epithelial cell-specific 1 gene; *TLSP*, trypsin-like serine protease.

(4) (Fig. 1). It is possible that some genes may still contain unidentified 5'-untranslated exons. The presence of one or more untranslated exons is not uncommon among kallikreins. In addition, many kallikreins have one or more splice variants (7, 11–14). These variants are predicted to encode for truncated proteins. We also examined the kallikrein locus for known repeat elements (15). Approximately 52% of the region is occupied by various repetitive elements (on either strand). Short interspersed nu-

clear elements, e.g., the ALU and MIR repeats, are the most abundant, followed by the long interspersed nuclear elements. Other repeat elements, such as Tigger2, MER8, and MSR1, were also identified (16).

The locus also contains a unique minisatellite element that is restricted to chromosome 19q13. Ten clusters of this minisatellite are distributed along the kallikrein locus. These clusters are located mainly in the promoters and enhancers of genes, in introns, and in the untranslated regions of the mRNA. PCR analysis of two clusters of these elements indicates that they are polymorphic; thus, they can be useful tools in linkage analysis and DNA fingerprinting. Our preliminary data showed that the distribution of the different alleles of these minisatellites might be associated with malignancy (15).

Common Structural Features of Kallikreins

The lengths of all human kallikrein genes range from 4 to 10 kb, with most of the differences attributed to intron lengths. Kallikreins have many common structural features that were considered to establish a universal nomenclature (17). Some features are common among other serine proteases, and others are unique for the kallikrein family. Table 2 summarizes the common structural features of kallikreins.

Tissue Expression and Hormonal Regulation of Kallikrein Genes

Many kallikreins are transcribed predominantly in a few tissues, as indicated by Northern blotting. With the more sensitive reverse transcription-PCR (RT-PCR) technique, kallikreins were found to be expressed at lower amounts in several other tissues. The tissue expression of all kallikreins, as assessed by RT-PCR and Northern blot

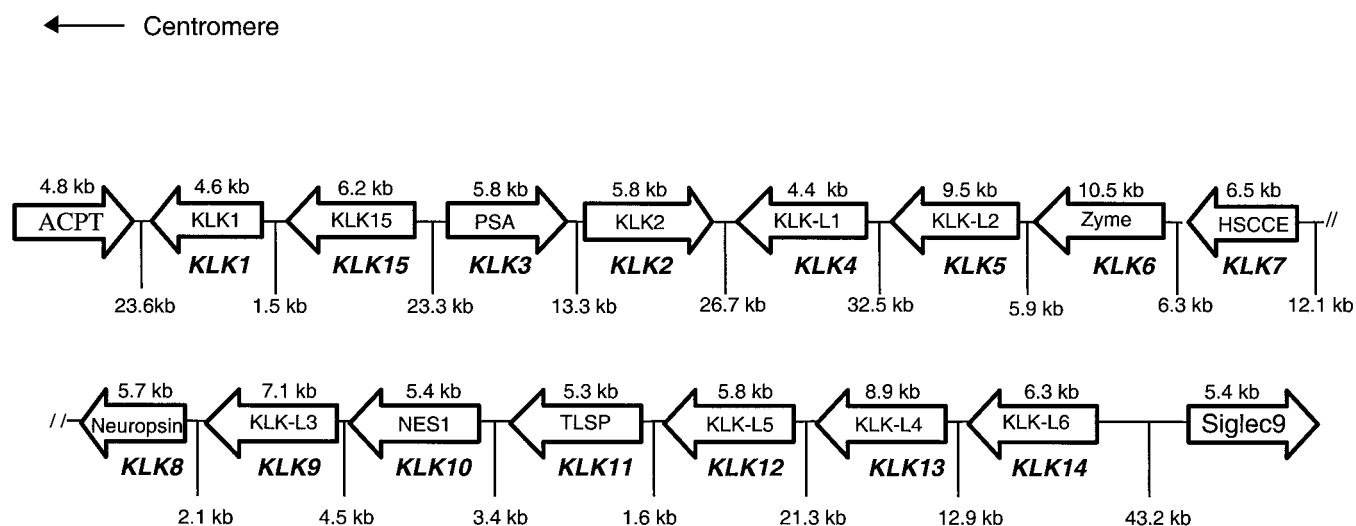

Fig. 1. Schematic of the human kallikrein gene locus on chromosome 19q13.4.

The original gene names are presented *inside* the *arrows* with official names indicated *under* each *arrow* in **bold**. *Arrowheads* show the direction of transcription. Gene lengths are indicated *above* each gene, and the lengths between genes are shown to the approximate kilobase. The genes *Siglec 9* and *ACPT* are not members of the kallikreins family. The figure is not drawn to scale. *HSCCE*, human stratum corneum chymotryptic enzyme; *NES1*, normal epithelial cell-specific 1 gene; *TLSP*, trypsin-like serine protease.

Table 2. Common structural features of the human kallikrein genes and proteins.

- All genes are formed of five coding exons, and most of them have one or more extra 5' untranslated exons. The first coding exon always contains a 5' untranslated region, followed by the methionine start codon, located ~50 bp away from the end of the exon. The stop codon is always located ~156 bp from the beginning of the last coding exon.
- Exon sizes are very similar or identical.
- The intron phases of the coding exons (i.e., the position where the intron starts in relation to the last codon of the previous exon) are conserved in all genes. The pattern of the intron phase is always I-II-I-O.
- The positions of the residues of the catalytic triad of serine proteases are conserved, with the histidine always occurring near the end of the second coding exon, the aspartate in the middle of the third coding exon, and the serine residue at the beginning of the fifth coding exon.
- All kallikrein proteins are synthesized as pre/propeptides with a signal peptide of ~17–20 amino acids at the amino terminus, followed by an activation peptide of ~4–9 amino acids (with the exception of hK5), followed by the mature (enzymatically active) protein.
- The amino acid of the substrate-binding pocket is either aspartate, indicating trypsin-like specificity (11 enzymes), or another amino acid [probably conferring chymotryptic (PSA) or other activity].
- Most, if not all, genes are under steroid hormone regulation.
- All proteins contain 10–12 cysteine residues that will form five to six disulfide bonds. The positions of the cysteine residues are also fully conserved.

analysis, is summarized elsewhere (2, 18, 19). Many kallikreins are expressed in endocrine-related organs. For example, all kallikreins except *KLK8* are expressed in the breast, and at least eight kallikreins are expressed in the ovary and ovarian cancer cell lines. Most of the kallikreins are also expressed, to a variable extent, in the prostate and testis.

Several reports have confirmed that many kallikreins are under steroid hormone regulation in cancer cell lines (7, 13, 14, 20–27). An interesting observation is the tissue-specific pattern of regulation of some genes (e.g., the prostate-specific regulation of PSA) and the different patterns of hormonal regulation in different tissues; e.g., *KLK4* is up-regulated by androgen in prostate and breast cancer cell lines (24) and by estrogen in endometrial cancer cell lines (25). In addition, *KLK12* was found to be up-regulated by androgens and progestins in prostate cancer cell lines and by estrogens and progestins in breast cancer cell lines (28). Details on the hormonal regulation of kallikrein genes have been published elsewhere (18). A noteworthy pattern related to the hormonal regulation is that the centromeric and telomeric groups of kallikreins (*KLK1* to *-4* and *KLK13* to *-15*) are up-regulated mainly by androgens, whereas the central group is up-regulated mainly by estrogens. It will be interesting to investigate whether there is a common control mechanism regulating groups of kallikreins in parallel. Functional characterization of the promoters of all kallikreins will better define the mechanism of kallikrein gene regulation by steroids.

Biological Role of Kallikreins

Only 3 of the 15 kallikreins have been assigned a specific biological function. hK1 exerts its biological activity mainly through the release of lysyl-bradykinin (kallidin) from low-molecular-weight kininogen. However, the diverse expression pattern of hK1 has led to the suggestion that the functional role of this enzyme may be specific to different cell types (29, 30). Apart from its kininogenase activity, tissue kallikrein has been implicated in the processing of growth factors and peptide hormones in light of its presence in pituitary, pancreas, and other tissues (31). As summarized by Bhoola et al. (29), hK1 has been shown to cleave proinsulin, LDL, the precursor of atrial natriuretic factor, prorenin, vasoactive intestinal peptide, procollagenase, and angiotensinogen. Kallikreins in each cell type may possess single or multiple functions, common or unique, but Bhoola et al. (29) suggest that the release of kinin should still be considered the primary effect of hK1.

The physiologic function of hK2 protein has been examined only recently. The study of substrate specificities between hK1 and hK2 reveals important differences, suggesting that the two proteins have different natural substrates, a notion that is supported by the finding of very low kininogenase activity of hK2 compared with hK1 (32, 33). Seminal plasma hK2 cleaves seminogelin I and seminogelin II, but at different cleavage sites and at a lower efficiency than does PSA (34). Because the amount of hK2 in seminal plasma is much lower than PSA (1–5%), the contribution of hK2 to the process of seminal clot liquefaction is expected to be relatively small.

In all biological fluids studied to date, hK3 (PSA) and hK2 were found to coexist, suggesting a possible functional relationship (35–37). Furthermore, a role of hK2 in regulating growth factors, through insulin-like growth factor binding protein-3 (IGFBP-3) proteolysis, has been suggested (38).

Recently, hK2 was found to activate the zymogen or the single-chain form of urokinase-type plasminogen activator (uPA) in vitro (39). Because uPA has been implicated in the promotion of cancer metastasis, hK2 may be part of this pathway in prostate cancer.

Although both hK1 and hK2 have trypsin-like enzymatic activities, hK3 has chymotrypsin-like substrate specificity. PSA is present at very high concentrations in seminal plasma; therefore, most studies focused on its biological activity within this fluid. Lilja (40) has shown that PSA rapidly hydrolyzes both seminogelin I and seminogelin II, as well as fibronectin, causing liquefaction of the seminal plasma clot after ejaculation. Several other potential substrates for PSA have been identified, including IGFBP-3, tumor growth factor- β , basement membrane, parathyroid hormone-related peptide, and plasminogen [reviewed in Ref. (41)]. The physiologic relevance of these findings is still not clear.

hK3 is now known to be found at relatively high concentrations in nipple aspirate fluid, breast cyst fluid,

Table 3. Kallikrein proteins as cancer biomarkers.

Kallikrein	Sample type	Method	Application	Reference(s)
hK2	Serum and tissue	Immunoassay; immunohistochemistry	Diagnosis, prognosis, and monitoring of prostate and breast cancer	(54)
hK3 (PSA)	Serum and tissue	Immunoassay; immunohistochemistry	Diagnosis, prognosis, and monitoring of prostate and breast cancer	(42, 54)
hK6	Serum	Immunoassay	Diagnosis, prognosis, and monitoring of ovarian cancer	(67, 68)
	Breast tumor cytosols	Immunoassay	Prognosis; association with hormone receptors	Our unpublished data
hK10	Serum	Immunoassay	Diagnosis and monitoring of ovarian cancer	(70)
	Ovarian cancer cytosols	Immunoassay	Prognosis; high concentrations associated with poor prognosis	(69)
hK11	Serum	Immunoassay	Diagnosis and prognosis of ovarian and prostate cancer	(71)

the milk of lactating women, amniotic fluid, and tumor extracts [reviewed in Ref. (42)]. It is thus very likely that hK3 has extraprostatic biological functions in breast and other tissues and may also play a role during fetal development.

Among all other human kallikreins, some have been connected to physiologic processes and pathologic conditions, but none has been assigned to cleave a specific substrate. Human kallikrein enzymes other than hK1, hK2, and hK3 are not commercially available, and the study of their biological function has not been published. Below, we will attempt to formulate some functional hypotheses for the human kallikreins.

All kallikreins are predicted to be secreted proteases,

and it is very likely that their biological function is related to their ability to digest one or more substrates. The diversity of expression in human tissues further suggests that they may act on different substrates in different tissues. Their enzymatic activity may initiate (by activation) or terminate (by inactivation) events mediated by other molecules, including hormones, growth factors, and cytokines. The parallel expression of many kallikreins in the same tissues further suggests that they may participate in cascade reactions similar to those established for the processes of digestion, fibrinolysis, coagulation, and apoptosis. The role of these enzymes in tumor metastasis, as suggested for other proteases (43, 44), should be further investigated.

Table 4. Kallikrein gene expression (mRNA) and cancer prognosis.

Kallikrein	Sample	Method	Application	Reference(s)
KLK4	Ovarian cancer tissue	RT-PCR	Unfavorable prognostic marker	(63, 65)
KLK5	Ovarian cancer tissue	RT-PCR	Unfavorable prognostic marker	(64)
	Breast tumor cytosols	RT-PCR	Poor prognosis	(80)
	Healthy and cancerous prostatic tissues	RT-PCR	Unfavorable prognostic marker	(81)
	Healthy and cancerous testicular tissues	RT-PCR	Lower expression in more aggressive tumors	(82)
KLK6	Ovarian cancer	RT-PCR Northern blot	Overexpression in ovarian cancer	(83)
KLK7	Ovarian cancer	RT-PCR	Overexpression in ovarian cancer	(62)
KLK8	Ovarian cancer	RT-PCR	Marker of favorable prognosis	(61)
	Ovarian cancer	Northern blot	Higher expression in ovarian cancer	(60)
KLK9	Ovarian cancer	RT-PCR	Marker of favorable prognosis	(66)
KLK10	Breast cancer	In situ hybridization	Down-regulated in cancer	(84)
KLK12	Breast cancer	RT-PCR	Down-regulated in breast cancer	(28)
KLK13	Breast cancer	RT-PCR	Down-regulated in a subset of breast tumors	(14)
KLK14	Ovarian cancer	RT-PCR	Marker of favorable prognosis	Our unpublished data
	Breast cancer	RT-PCR	Down-regulated in breast cancer	(27)
	Healthy and cancerous testicular tissues	RT-PCR	Down-regulated in cancerous tissue	(27)
KLK15	Ovarian cancer	RT-PCR	Marker of poor prognosis	Our unpublished data
	Breast cancer	RT-PCR	Marker of favorable prognosis	Our unpublished data
	Healthy and cancerous prostatic tissues	RT-PCR	Marker of unfavorable prognosis	Our unpublished data

Kallikreins as Part of a Novel Potential Enzymatic Cascade Pathway

Interactions between serine proteases are common, and substrates of serine proteases are usually other serine proteases that are activated from an inactive precursor (45). The involvement of serine proteases in cascade pathways is well documented. One important example is the blood coagulation cascade. In this enzymatic cascade, the activated form of one factor catalyzes the activation of the next factor. Very small amounts of the initial factors are thus sufficient to trigger the cascade because of the catalytic nature of the process. These numerous steps yield a large amplification, thus ensuring a rapid and amplified response to trauma. A similar mechanism is involved in the dissolution of blood clots, in which activation of plasminogen activators leads to conversion of plasminogen to plasmin, which is responsible for lysis of the fibrin clot. A third important example of the coordinated action of serine proteases involves the intestinal digestive enzymes. The digestion of proteins in the duodenum requires the concurrent action of several proteolytic enzymes. Coordinated control is achieved by the action of trypsin as the common activator of all pancreatic zymogens. The apoptosis pathway is another important example of coordinated action of proteases.

The cross-talk between kallikreins and the hypothesis that they are involved in a cascade enzymatic pathway are supported by strong, but mostly circumstantial, evidence, including the coexpression of many kallikreins in the same tissue and the ability of some kallikreins to activate each other (46–49). Added to this are the common patterns of hormonal regulation and the parallel pattern of differential expression of many kallikreins in diverse malignancies (Tables 3 and 4).

The interrelationships between some kallikreins are well documented. Recent experimental evidence has shown that hK3 (PSA) can be activated by hK15 (47). Prostase (hK4) has also recently been shown to activate hK3 much more efficiently compared with hK2 (48). hK5 is predicted to be able to activate hK7 in the skin (50). It will be interesting to study all possible combinations of interactions among kallikreins, especially those coexpressed in the same tissues. Bhoola et al. (51) have recently provided strong evidence of the involvement of a “kallikrein cascade” in initiating and maintaining systemic inflammatory responses and immune-modulated disorders.

Kallikreins might also be involved in cascade reactions involving other, nonkallikrein serine proteases. There is also a reported, but questionable, ability of hK3 to activate IGFBP-3 (52). hK3 can inactivate the N-terminal fragment of the parathyroid hormone-related protein (53). Experimental evidence has also shown that hK2 and hK4 can activate the proform of another serine protease, uPA (44, 50). The hypothetical involvement of a kallikrein cascade in the pathogenesis and progression of ovarian cancer is depicted in Fig. 2.

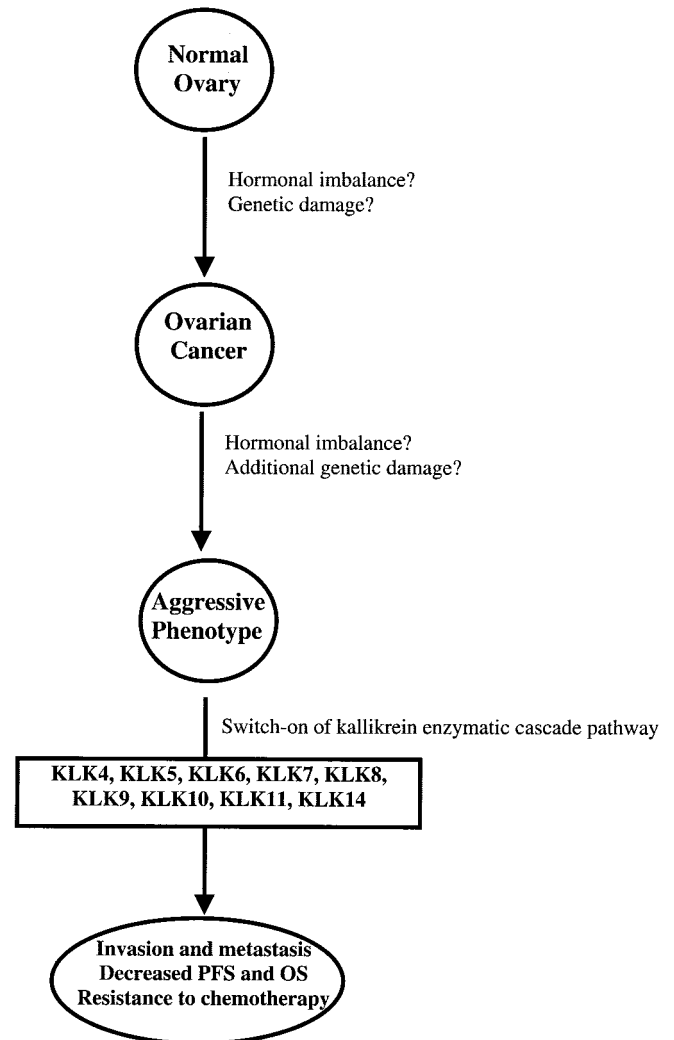

Fig. 2. Hypothetical model implicating multiple kallikrein overexpression during progression of ovarian cancer.

The documented kallikrein overexpression and relation to patient prognosis (Table 4) are attributed to hormonal imbalance and genetic damage. The activation of a kallikrein-based enzymatic cascade during ovarian cancer progression is hypothetical at present. PFS, progression-free survival of ovarian cancer patients; OS, overall survival of ovarian cancer patients.

Kallikreins as Cancer Biomarkers

The genes encoding for PSA (hK3), hK2, and prostase (hK4) are tandemly localized and are highly expressed in the prostate. This restricted tissue expression and secretion of the proteases into biological fluids make them ideal markers for prostatic diseases. A more detailed discussion on hK2 and hK3 as cancer biomarkers can be found elsewhere (54). In addition to hK3 being an established marker for prostate cancer diagnosis and monitoring, recent reports suggest some usefulness of hK3 as a marker for breast cancer prognosis (42, 55, 56).

With the full identification and characterization of all members of the kallikrein gene family, accumulating reports started to indicate that other kallikreins might be also related to hormonal malignancies (for example,

breast, prostate, testicular, and ovarian cancers). *KLK6* (zyme/protease M) was isolated by differential display from an ovarian cancer library (57), and *KLK10* (*NEST1*) was cloned by subtractive hybridization from a breast cancer library (58) and later shown to act as a tumor suppressor gene (59). Underwood et al. (60) and Magklara et al. (61) have shown that *KLK8* (also known as neuropsin and *TADG-14*) is differentially expressed in ovarian cancer. *KLK7* is up-regulated in ovarian cancer (62), and *KLK4* and *KLK5* are indicators of poor prognosis of ovarian cancer (63–65). More recently, *KLK9* has been shown to be a marker of favorable prognosis for the same malignancy (66).

At the protein level, recent reports showed that kallikrein proteins can be useful serum biomarkers for the diagnosis and prognosis of cancer. In addition to hK3 and hK2, hK6 and hK10 are emerging diagnostic markers for ovarian cancer (67–70). More recently, hK11 was also shown to be a potential marker for ovarian and prostate cancer (71).

Added to the above evidence are the findings that all known kallikreins are under sex steroid hormone regulation in cancer cell lines (7, 13, 14, 22–24, 28, 72). Tables 3 and 4 summarize all the available data on measurement of kallikrein genes and proteins in serum and tumor tissue extracts for the purpose of disease diagnosis, monitoring, prognosis, or subclassification. It is clear from these data that at least a few kallikreins have already found important clinical applications, whereas other members show promising potential. The availability of sensitive analytical methods for the remaining kallikreins will allow their examination as candidate cancer biomarkers.

References

- Riegman PH, Vlietstra R J, Suurmeijer L, Cleutjens CB, Trapman J. Characterization of the human kallikrein locus. *Genomics* 1992; 14:6–11.
- Yousef GM, Luo L-Y, Diamandis EP. Identification of novel human kallikrein-like genes on chromosome 19q13.3-q13.4. *Anticancer Res* 1999;19:2843–52.
- Diamandis EP, Yousef GM, Luo LY, Magklara A, Obiezu CV. The human kallikrein gene family—implications in carcinogenesis. *Trends Endocrinol Metab* 2000;11:54–60.
- Yousef GM, Chang A, Scorilas A, Diamandis EP. Genomic organization of the human kallikrein gene family on chromosome 19q13.3-q13.4. *Biochem Biophys Res Commun* 2000;276:125–33.
- Harvey TJ, Hooper JD, Myers SA, Stephenson SA, Ashworth LK, Clements JA. Tissue-specific expression patterns and fine mapping of the human kallikrein (*KLK*) locus on proximal 19q13.4. *J Biol Chem* 2000;275:37397–406.
- Gan L, Lee I, Smith R, Argonza-Barrett R, Lei H, McCuaig JB, et al. Sequencing and expression analysis of the serine protease gene cluster located in chromosome 19q13 region. *Gene* 2000;257: 119–30.
- Yousef GM, Scorilas A, Jung K, Ashworth LK, Diamandis EP. Molecular cloning of the human kallikrein 15 gene (*KLK15*). Up-regulation in prostate cancer. *J Biol Chem* 2001;276:53–61.
- Yousef GM, Diamandis M, Jung K, Diamandis EP. Molecular cloning of a novel human acid phosphatase gene (*acpt*) that is highly expressed in the testis. *Genomics* 2001;74:385–95.
- Foussias G, Yousef GM, Diamandis EP. Identification and molecular characterization of a novel member of the siglec family (*SIGLEC9*). *Genomics* 2000;67:171–8.
- Yousef GM, Ordon MH, Foussias G, Diamandis EP. Genomic organization of the siglec gene locus on chromosome 19q13.4 and cloning of two new siglec pseudogenes. *Gene* 2002;286: 259–70.
- Chang A, Yousef GM, Jung K, Meyts ER, Diamandis EP. Identification and molecular characterization of five novel kallikrein gene 13 (*KLK13*; *KLK-L4*) splice variants: differential expression in human testis and testicular cancer. *Anticancer Res* 2001;21: 3147–52.
- Obiezu CV, Diamandis EP. An alternatively spliced variant of *KLK4* expressed in prostatic tissue. *Clin Biochem* 2000;33:599–600.
- Yousef GM, Scorilas A, Magklara A, Soosai pillai A, Diamandis EP. The *KLK7* (*PRSS6*) gene, encoding for the stratum corneum chymotryptic enzyme is a new member of the human kallikrein gene family—genomic characterization, mapping, tissue expression and hormonal regulation. *Gene* 2000;254:119–28.
- Yousef GM, Chang A, Diamandis EP. Identification and characterization of *KLK-L4*, a new kallikrein-like gene that appears to be down-regulated in breast cancer tissues. *J Biol Chem* 2000;275: 11891–8.
- Yousef GM, Bharaj BS, Yu H, Pouloupoulos J, Diamandis EP. Sequence analysis of the human kallikrein gene locus identifies a unique polymorphic minisatellite element. *Biochem Biophys Res Commun* 2001;285:1321–9.
- Hu JC, Zhang C, Sun X, Yang Y, Cao X, Ryu O, Simmer JP. Characterization of the mouse and human *PRSS17* genes, their relationship to other serine proteases, and the expression of *PRSS17* in developing mouse incisors. *Gene* 2000;251:1–8.
- Diamandis EP, Yousef GM, Clements J, Ashworth LK, Yoshida S, Egelrud T, et al. New nomenclature for the human tissue kallikrein gene family. *Clin Chem* 2000;46:1855–8.
- Yousef GM, Diamandis EP. The new human tissue kallikrein gene family: structure, function and association to disease. *Endocr Rev* 2001;22:184–204.
- Yousef GM, Diamandis EP. Human kallikreins: common structural features, sequence analysis and evolution. *Curr Genomics*; in press.
- Riegman PH, Vlietstra RJ, van der Korput HA, Romijn JC, Trapman J. Identification and androgen-regulated expression of two major human glandular kallikrein-1 (*hGK-1*) mRNA species. *Mol Cell Endocrinol* 1991;76:181–90.
- Riegman PH, Vlietstra RJ, van der Korput JA, Brinkmann AO, Trapman J. The promoter of the prostate-specific antigen gene contains a functional androgen responsive element. *Mol Endocrinol* 1991;5:1921–30.
- Yousef GM, Luo LY, Scherer SW, Sotiropoulou G, Diamandis EP. Molecular characterization of zyme/protease M/neurosin (*PRSS9*), a hormonally regulated kallikrein-like serine protease. *Genomics* 1999;62:251–9.
- Yousef GM, Diamandis EP. The new kallikrein-like gene, *KLK-L2*. Molecular characterization, mapping, tissue expression, and hormonal regulation. *J Biol Chem* 1999;274:37511–6.
- Nelson PS, Gan L, Ferguson C, Moss P, Gelinis R, Hood L, et al. Molecular cloning and characterization of prostase, an androgen-regulated serine protease with prostate-restricted expression. *Proc Natl Acad Sci U S A* 1999;96:3114–9.
- Myers SA, Clements JA. Kallikrein 4 (*KLK4*), a new member of the human kallikrein gene family is up-regulated by estrogen and progesterone in the human endometrial cancer cell line, KLE. *J Clin Endocrinol Metab* 2001;86:2323–6.

26. Murtha P, Tindall DJ, Young CY. Androgen induction of a human prostate-specific kallikrein, hKLK2: characterization of an androgen response element in the 5' promoter region of the gene. *Biochemistry* 1993;32:6459–64.
27. Yousef GM, Magklara A, Chang A, Jung K, Katsaros D, Diamandis EP. Cloning of a new member of the human kallikrein gene family, KLK14, which is down-regulated in different malignancies. *Cancer Res* 2001;61:3425–31.
28. Yousef GM, Magklara A, Diamandis EP. KLK12 is a novel serine protease and a new member of the human kallikrein gene family-differential expression in breast cancer. *Genomics* 2000;69:331–41.
29. Bhoola KD, Figueroa CD, Worthy K. Bioregulation of kinins: kallikreins, kininogens, and kininases. *Pharmacol Rev* 1992;44:1–80.
30. Schachter M. Kallikreins (kininogenases)—a group of serine proteases with bioregulatory actions. *Pharmacol Rev* 1979;31:1–17.
31. Mason AJ, Evans BA, Cox DR, Shine J, Richards RI. Structure of mouse kallikrein gene family suggests a role in specific processing of biologically active peptides. *Nature* 1983;303:300–7.
32. Deperthes D, Marceau F, Frenette G, Lazure C, Tremblay RR, Dube JY. Human kallikrein hK2 has low kininogenase activity while prostate specific antigen (hK2) has none. *Biochem Biophys Acta* 1997;1343:102–6.
33. Charlesworth MC, Young CYE, Miller VM, Tindall DJ. Kininogenase activity of prostate-derived human glandular kallikrein (hK2) purified from seminal fluid. *J Androl* 1999;20:220–9.
34. Deperthes D, Frenette G, Brillard-Bourdet M, Bourgeois L, Gauthier F, Tremblay RR, et al. Potential involvement of kallikrein hK2 in the hydrolysis of the human seminal vesicle proteins after ejaculation. *J Androl* 1996;17:659–65.
35. Magklara A, Scorilas A, López-Otin C, Vizoso F, Ruibal A, Diamandis EP. Human glandular kallikrein in breast milk, amniotic fluid, and breast cyst fluid. *Clin Chem* 1999;45:1774–80.
36. Black MA, Magklara A, Obiezu C, Levesque MA, Sutherland DJA, Tindall DJ, et al. Expression of a prostate-associated protein, human glandular kallikrein (hK2), in breast tumors and in normal breast secretions. *Br J Cancer* 2000;82:361–7.
37. Lovgren J, Valtonen-Andre C, Marsal K, Lilja H, Lundwall A. Measurement of prostate-specific antigen and human glandular kallikrein 2 in different body fluids. *J Androl* 1999;20:348–55.
38. Dube JY, Tremblay RR. Biochemistry and potential roles of prostatic kallikrein hK2. *Mol Urol* 1997;1:279–85.
39. Frenette G, Tremblay RR, Lazure C, Dube JY. Prostatic kallikrein hK2, but not prostate-specific antigen (hK3), activates single-chain urokinase-type plasminogen activator. *Int J Cancer* 1997;71:897–9.
40. Lilja H. A kallikrein-like serine protease in prostatic fluid cleaves the predominant seminal vesicle protein. *J Clin Invest* 1985;76:1899–903.
41. Diamandis EP. Prostate-specific antigen: a cancer fighter and a valuable messenger? *Clin Chem* 2000;46:896–900.
42. Black MH, Diamandis EP. The diagnostic and prognostic utility of prostate specific antigen for diseases of the breast. *Breast Cancer Res Treat* 2000;59:1–14.
43. Woodhouse EC, Chuaqui RF, Liotta LA. General mechanisms of metastasis. *Cancer* 1997;80:1529–37.
44. Chambers AF, Matrisian LM. Changing views of the role of matrix metalloproteinases in metastasis. *J Natl Cancer Inst* 1997;80:1260–70.
45. Schultz RM, Liebman MN. Structure-function relationship in protein families. In: Devlin TM, ed. *Textbook of biochemistry with clinical correlations*, 4th ed. New York: Wiley-Liss, 1997:112–6.
46. Takayama TK, Fujikawa K, Davie EW. Characterization of the precursor of prostate-specific antigen. Activation by trypsin and by human glandular kallikrein. *J Biol Chem* 1997;272:21582–8.
47. Takayama TK, Carter CA, Deng T. Activation of prostate-specific antigen precursor (pro-PSA) by prostin, a novel human prostatic serine protease identified by degenerate PCR. *Biochemistry* 2001;40:1679–87.
48. Takayama TK, McMullen BA, Nelson PS, Matsumura M, Fujikawa K. Characterization of hK4 (prostase), a prostate-specific serine protease: activation of the precursor of prostate specific antigen (pro-PSA) and single-chain urokinase-type plasminogen activator and degradation of prostatic acid phosphatase. *Biochemistry* 2001;40:15341–8.
49. Lovgren J, Rajakoski K, Karp M, Lundwall A, Lilja H. Activation of the zymogen form of prostate-specific antigen by human glandular kallikrein 2. *Biochem Biophys Res Commun* 1997;238:549–55.
50. Brattsand M, Egelrud T. Purification, molecular cloning, and expression of a human stratum corneum trypsin-like serine protease with possible function in desquamation. *J Biol Chem* 1999;274:30033–40.
51. Bhoola K, Ramsaroop R, Plendl J, Cassim B, Dlamini Z, Naicker S. Kallikrein and kinin receptor expression in inflammation and cancer. *Biol Chem* 2001;382:77–89.
52. Cohen P, Graves HC, Peehl DM, Kamarei M, Giudice LC, Rosenfeld RG. Prostate-specific antigen (PSA) is an insulin-like growth factor binding protein-3 protease found in seminal plasma. *J Clin Endocrinol Metab* 1992;75:1046–53.
53. Iwamura M, Hellman J, Cockett AT, Lilja H, Gershagen S. Alteration of the hormonal bioactivity of parathyroid hormone-related protein (PTHrP) as a result of limited proteolysis by prostate-specific antigen. *Urology* 1996;48:317–25.
54. Rittenhouse HG, Finlay JA, Mikolajczyk SD, Partin AW. Human Kallikrein 2 (hK2) and prostate-specific antigen (PSA): two closely related, but distinct, kallikreins in the prostate. *Crit Rev Clin Lab Sci* 1998;35:275–368.
55. Yu H, Gai M, Diamandis EP, Katsaros D, Sutherland DJ, Levesque MA, et al. Prostate-specific antigen is a new favorable prognostic indicator for women with breast cancer. *Cancer Res* 1995;55:2104–10.
56. Black MH, Gai M, Ponzzone R, Sismondi P, Yu H, Diamandis EP. Serum total and free prostate-specific antigen for breast cancer diagnosis in women. *Clin Cancer Res* 2000;6:467–73.
57. Anisowicz A, Sotiropoulou G, Stenman G, Mok SC, Sager R. A novel protease homolog differentially expressed in breast and ovarian cancer. *Mol Med* 1996;2:624–36.
58. Liu XL, Wazer DE, Watanabe K, Band V. Identification of a novel serine protease-like gene, the expression of which is down-regulated during breast cancer progression. *Cancer Res* 1996;56:3371–9.
59. Goyal J, Smith KM, Cowan JM, Wazer DE, Lee SW, Band V. The role for NES1 serine protease as a novel tumor suppressor. *Cancer Res* 1998;58:4782–6.
60. Underwood LJ, Tanimoto H, Wang Y, Shigemasa K, Parmley TH, O'Brien TJ. Cloning of tumor-associated differentially expressed gene-14, a novel serine protease overexpressed by ovarian carcinoma. *Cancer Res* 1999;59:4435–9.
61. Magklara A, Scorilas A, Katsaros D, Massobrio M, Yousef GM, Fracchioli S, et al. The human KLK8 (neuropsin/ovasin) gene: identification of two novel splice variants and its prognostic value in ovarian cancer. *Clin Cancer Res* 2001;7:806–11.
62. Tanimoto H, Underwood LJ, Shigemasa K, Yan Yan MS, Clarke J, Parmley TH, et al. The stratum corneum chymotryptic enzyme that mediates shedding and desquamation of skin cells is highly overexpressed in ovarian tumor cells. *Cancer* 1999;86:2074–82.
63. Obiezu CV, Scorilas A, Katsaros D, Massobrio M, Yousef GM, Fracchioli S, et al. Higher human kallikrein gene 4 (klk4) expres-

- sion indicates poor prognosis of ovarian cancer patients. *Clin Cancer Res* 2001;7:2380–6.
64. Kim H, Scorilas A, Katsaros D, Yousef GM, Massobrio M, Fracchioli S, et al. Human kallikrein gene 5 (KLK5) expression is an indicator of poor prognosis in ovarian cancer. *Br J Cancer* 2001;84:643–50.
 65. Dong Y, Kaushal A, Bui L, Chu S, Fuller PJ, Nicklin J, et al. Human kallikrein 4 (KLK4) is highly expressed in serous ovarian carcinomas. *Clin Cancer Res* 2001;7:2363–71.
 66. Yousef GM, Kyriakopoulou LG, Scorilas A, Fracchioli S, Ghiringhello B, Zarghooni M, et al. Quantitative expression of the human kallikrein gene 9 (KLK9) in ovarian cancer: a new independent and favorable prognostic marker. *Cancer Res* 2001;61:7811–8.
 67. Diamandis EP, Yousef GM, Soosaipillai AR, Grass L, Porter A, Little S, et al. Immunofluorometric assay of human kallikrein 6 (zyme/protease M/neurosin) and preliminary clinical applications. *Clin Biochem* 2000;33:369–75.
 68. Diamandis EP, Yousef GM, Soosaipillai AR, Bunting P. Human kallikrein 6 (zyme/protease M/neurosin): a new serum biomarker of ovarian carcinoma. *Clin Biochem* 2000;33:579–83.
 69. Luo LY, Katsaros D, Scorilas A, Fracchioli S, Piccinno R, Rigault de la Longrais IA, et al. Prognostic value of human kallikrein 10 expression in epithelial ovarian carcinoma. *Clin Cancer Res* 2001;7:2372–9.
 70. Luo L, Bunting P, Scorilas A, Diamandis EP. Human kallikrein 10: a novel tumor marker for ovarian carcinoma? *Clin Chim Acta* 2001;306:111–8.
 71. Diamandis EP, Okui A, Mitsui S, Luo LY, Soosaipillai A, Grass L, et al. Human kallikrein 11: a new biomarker of prostate and ovarian carcinoma. *Cancer Res* 2002;62:295–300.
 72. Hooper JD, Bui LT, Rae FK, Harvey TJ, Myers SA, Ashworth LK, et al. Identification and characterization of klk14, a novel kallikrein serine protease gene located on human chromosome 19q13.4 and expressed in prostate and skeletal muscle. *Genomics* 2001;73:117–22.
 73. Yamashiro K, Tsuruoka N, Kodama S, Tsujimoto M, Yamamura Y, Tanaka T, et al. Molecular cloning of a novel trypsin-like serine protease (neurosin) preferentially expressed in brain. *Biochim Biophys Acta* 1997;1350:11–4.
 74. Hansson L, Stromqvist M, Backman A, Wallbrandt P, Carlstein A, Egelrud T. Cloning, expression, and characterization of stratum corneum chymotryptic enzyme. A skin-specific human serine protease. *J Biol Chem* 1994;269:19420–6.
 75. Yoshida S, Taniguchi M, Hirata A, Shiosaka S. Sequence analysis and expression of human neurosin cDNA and gene. *Gene* 1998;213:9–16.
 76. Yousef GM, Diamandis EP. The expanded human kallikrein gene family: locus characterization and molecular cloning of a new member, KLK-L3 (KLK9). *Genomics* 2000;65:184–94.
 77. Luo L, Herbrick JA, Scherer SW, Beatty B, Squire J, Diamandis EP. Structural characterization and mapping of the normal epithelial cell-specific 1 gene. *Biochem Biophys Res Commun* 1998;247:580–6.
 78. Yoshida S, Taniguchi M, Suemoto T, Oka T, He X, Shiosaka S. cDNA cloning and expression of a novel serine protease, TLSP. *Biochim Biophys Acta* 1998;1399:225–8.
 79. Yousef GM, Scorilas A, Diamandis EP. Genomic organization, mapping, tissue expression, and hormonal regulation of trypsin-like serine protease (TLSP PRSS20), a new member of the human kallikrein gene family. *Genomics* 2000;63:88–96.
 80. Yousef GM, Scorilas A, Kyriakopoulou LG, Rendl L, Diamandis M, Ponzzone R, et al. Human kallikrein gene 5 (KLK5) expression by quantitative PCR: an independent indicator of poor prognosis in breast cancer. *Clin Chem* 2002;48:1241–50.
 81. Yousef GM, Scorilas A, Chang A, Rendl L, Diamandis M, Jung K, et al. Down-regulation of the human kallikrein gene 5 (KLK5) in prostate cancer tissues. *Prostate* 2002;51:126–32.
 82. Yousef GM, Obiezu C, Jung K, Stephan C, Scorilas A, Diamandis EP. Differential expression of kallikrein gene 5 (KLK5) in cancerous and normal testicular tissues. *Urology* 2002;in press.
 83. Tanimoto H, Underwood LJ, Shigemasa K, Parmley TH, O'Brien TJ. Increased expression of protease M in ovarian tumors. *Tumour Biol* 2001;22:11–8.
 84. Dhar S, Bhargava R, Yunes M, Li B, Goyal J, Naber SP, et al. Analysis of normal epithelial cell specific-1 (NES1)/kallikrein 10 mRNA expression by in situ hybridization, a novel marker for breast cancer. *Clin Cancer Res* 2001;7:3393–8.